

Installation Instructions

The PC5208/4 can be used to add up to 4 low current programmable outputs to the control panel (see the *Installation Manual* for complete installation instructions).

Specifications

- Module Current Draw: 20 mA
- Auxiliary Current: 250 mA (PTC-protected - fuseless design)
- Outputs: each output can sink up to 50 mA

Terminal Description

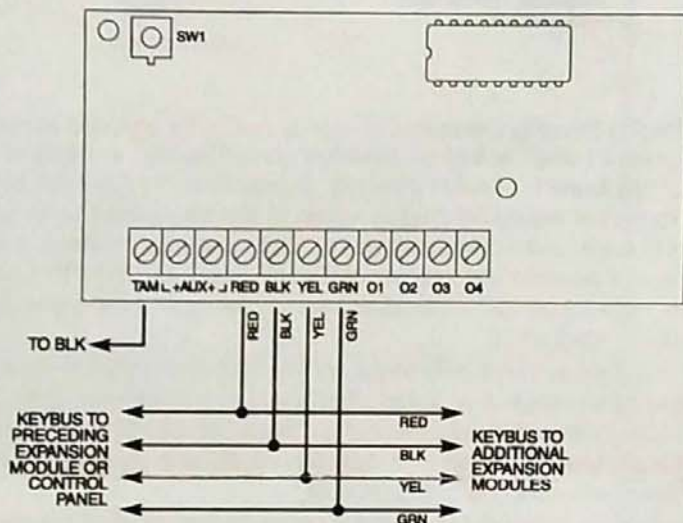

TAM - This can be used to tamper the cabinet in which the PC5208/4 is mounted. Connect a normally closed (NC) switch across TAM and BLK. If the tamper is not being used connect a piece of wire across TAM and BLK to remove the trouble condition.

! *There is a built-in tamper switch on the expander module located in the top left corner of the circuit board. If the cabinet used to mount the PC5208/4 Output Module has the hardware required to depress this tamper switch then DO NOT connect anything to the TAM terminal.*

+AUX+ - There are two terminals for AUX power to simplify wiring. These terminals are used to provide power for devices. Maximum current draw is not to exceed 250 mA. Connect the positive lead of powered devices to either AUX+ terminal, and the negative to the proper output terminal (O1 to O4).

KEYBUS - The 4 wire Keybus connection is used by the panel to communicate with the module. Connect the RED, BLK, YEL and GRN terminals to the Keybus terminals on the main control panel.

DSC
PowerSeries™

PC5208/4

4 Low Current Output Module

Version 1.0

O1 to O4 - Wire the positive lead of the device to either AUX+ terminal and the negative lead to the required output terminal (O1 to O4).

The following are examples of how to wire various devices to the outputs:

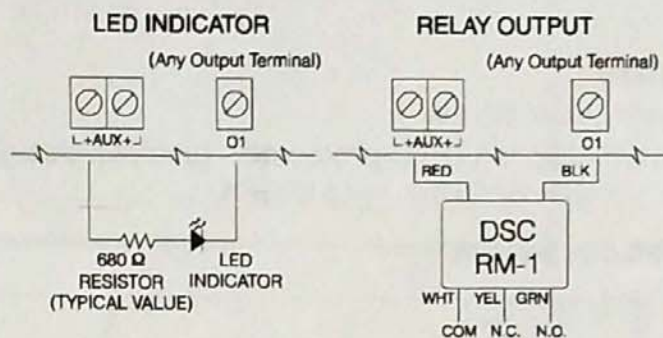

Limited Warranty Digital Security Controls Ltd. warrants that for a period of twelve months from the date of purchase, the product shall be free of defects in materials and workmanship under normal use and that in fulfillment of any breach of such warranty, Digital Security Controls Ltd. shall, at its option, repair or replace the defective equipment upon return of the equipment to its factory. This warranty applies only to defects in parts and workmanship and not to damage incurred in shipping or handling, or damage due to causes beyond the control of Digital Security Controls Ltd. Such as lightning, excessive voltage, mechanical shock, water damage, or damage arising out of abuse, alteration or improper application of the equipment.

The foregoing warranty shall apply only to the original buyer, and is and shall be in lieu of any and all other warranties, whether expressed or implied and of all other obligations or liabilities on the part of Digital Security Controls Ltd. This warranty contains the entire warranty. Digital Security Controls Ltd. neither assumes, nor authorizes any other person purporting to act on its behalf to modify or to change this warranty, nor to assume for it any other warranty or liability concerning this product.

In no event shall Digital Security Controls Ltd. be liable for any direct or indirect or consequential damages, loss of anticipated profits, loss of time or any other losses incurred by the buyer in connection with the purchase, installation or operation or failure of this product.

WARNING: Digital Security Controls Ltd. recommends that the entire system be completely tested on a regular basis. However, despite frequent testing, and due to, but not limited to, criminal tampering or electrical disruption, it is possible for this product to fail to perform as expected.

FCC COMPLIANCE STATEMENT

CAUTION: Changes or modifications not expressly approved by Digital Security Controls Ltd. could void your authority to use this equipment.

This equipment generates and uses radio frequency energy and if not installed and used properly, in strict accordance with the manufacturer's instructions, may cause interference to radio and television reception. It has been type tested and found to comply with the limits for Class B device in accordance with the specifications in Subpart "B" of Part 15 of FCC Rules, which are designed to provide reasonable protection against such interference in any residential installation. However, there is no guarantee that interference will not occur in a particular installation. If this equipment does cause interference to television or radio reception, which can be determined by turning the equipment off and on, the user is encouraged to try to correct the interference by one or more of the following measures:

- Re-orient the receiving antenna
- Relocate the alarm control with respect to the receiver
- Move the alarm control away from the receiver
- Connect the alarm control into a different outlet so that alarm control and receiver are on different circuits.

If necessary, the user should consult the dealer or an experienced radio/television technician for additional suggestions. The user may find the following booklet prepared by the FCC useful: "How to Identify and Resolve Radio/Television Interference Problems". This booklet is available from the U.S. Government Printing Office, Washington D.C. 20402, Stock # 004-000-00345-4.



©2000 Digital Security Controls Ltd.
Toronto, Canada
1-800-387-3630 • www.dsc.com
Printed in Canada 29005735 R001