

Smart GUARD SYSTEM



CENTURION
THE AUTOMATIC CHOICE

OPERATING INSTRUCTIONS



In a hurry?

The following KwikLearn procedure and connection diagram will enable you to start using your SmartGUARD system right away.

Additional procedures are explained later in this manual.

KwikLearn

Adds a new access code at a specified address. The code will operate the relay output only.

Enter the following keystrokes:

		INDICATOR LED's
		○ ○ ☀
1. Enter program mode	* Master Code † *	☀ ○ ○
2. Select KwikLearn	0 #	☀ ☀ ○
3. Enter user address	Address #	☀ ☀ ☀
4. Enter access code	Code #	○ ○ ☀

† Default master code = 1234

Example:

KwikLearn access code 93245 into address 25.

(Master code = 1234)

		INDICATOR LED's
		○ ○ ☀
Enter program mode	* 1 2 3 4 *	☀ ○ ○
Select KwikLearn	0 #	☀ ☀ ○
Enter user address	2 5 #	☀ ☀ ☀
Enter access code	9 3 2 4 5 #	○ ○ ☀

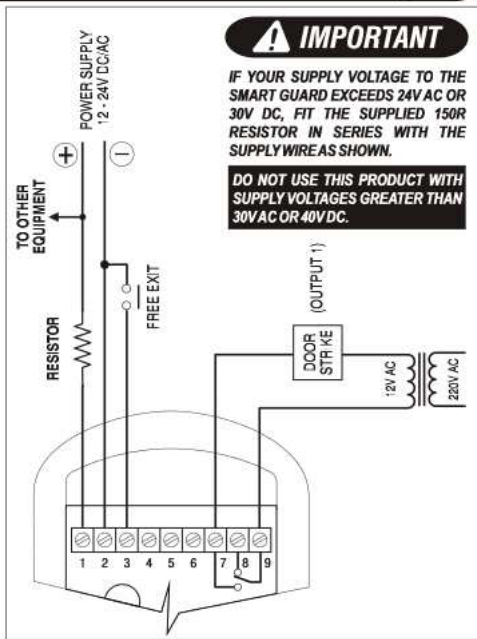

Quick Reference Connection Diagram:



How to Follow the Procedures

The procedures in this manual require the user to perform certain sequential actions on the keypad. To assist you, the combined state of the three LED indicators on the keypad corresponds with particular steps within a procedure. When carrying out the procedures, please be aware of the following:

The factory default master code (1 2 3 4) is used throughout this manual as an example only. Refer to page 5 for instructions on how to change the master code.

	Indicates a particular key to be pressed on the keypad by the user.
	Indicates a lit LED
[]	Indicates optional entries

IMPORTANT WHEN CHOOSING AN ACCESS CODE NUMBER

- If you intend using the DURESS security parameter (Page 16), ensure that no consecutive numbers are assigned as codes.
- Ensure that the desired code has not been allocated already.

© Centurion Systems (Pty) Ltd 2003
Document Ref: 1029.D.01.0001_3
Last Revised 29.11.2004

Table of contents

Overview	2
Specifications:	4
Changing the Master Code	5
Adding a new user:	6
Deleting a user:	8
Setting the output timers:	10
Setting the anti-hack parameters:	12
Setting the key wipeout timer:	14
Setting the security parameters:	16
Backing up the unit:	19
Restoring the unit:	20
Defaulting the unit:	21
Defaulting the Master Code:	21
Defaulting the System Parameters:	21
Typical mounting instructions:	22
Fitting the optional anti-tamper switch	24
Typical connection diagram:	25
Glossary	26
Installation Information	27

Overview

The Centurion SmartGUARD is a durable, quality keypad designed to provide high security access control to restricted areas. The unit is weatherproof, and the keys are backlit for ease of use at night. Access is granted by the keying in of a valid access code. The access code can vary from one to ten digits. Up to one thousand different access codes can be stored within the unit's non-volatile memory. New codes can be added, and existing codes deleted as required. "Token" codes can be added, allowing only a preset number of activations, after which the code becomes invalid. Each code can operate one or more of the three available outputs. The first output is a potential free relay contact capable of switching up to 3A at 50V. Both normally closed and normally open contacts are available. The second and third outputs are open collector channels, capable of directly switching any negative triggered equipment, or an external relay. The output channels can be set as pulsed or latching, with pulse times adjustable in one second increments between one second and four minutes. The open collector output channels can be used with the optional CP105 Smart Switch, allowing secure control of equipment a distance away from the main unit. An anti-hack feature can be enabled, causing the unit to shut down after a pre-selected number of incorrect codes have been entered. The unit will then reset after a pre-selected time. A telltale LED will indicate that the anti-hack feature has been triggered. The third output channel can

be used as an alarm channel, triggered by various panic or alarm conditions. The relay output can be activated by an external pushbutton, giving free exit capability. Once programmed, the system can be backed up onto the optional CP108 backup module. This allows the system to be easily restored if required. An optional independent tamper switch can be fitted to provide a contact indicating if the unit has been forced open, or removed from its mountings.

Specifications

Physical:

Supply voltage:	12V-24V AC/DC
Standby current:	32mA
Maximum current:	180mA ¹
Operating temperature:	-15C to +55C
Operating humidity:	0-90% ²
Output relay rating:	1 x 3A @ 50V ³
Open collector rating:	2 x 50mA @ 24V
Housing material:	Polycarbonate
Degree of protection:	IP55

Functional:

Code length:	1-10 Digits
Memory capacity:	1000 unique non-volatile codes
Memory retention:	>200 years
Output pulse range:	1-255s adjustable, or latched
Token codes:	1- 254 activations

(1) All outputs active, Smart Switches on Ch2 & Ch3.

(2) Non-condensing.

(3) Non-inductive load.



Changing the Master Code

Replaces the default or currently stored master code with a new master code. The master code may also be learned by following the procedure on page 6, Adding a New User.

Notes:

- The master code must always be stored at address 0.
- The master code can be used as a normal access code.

Enter the following keystrokes:

		INDICATOR LED's
		○ ○ ●
1. Enter Program mode	* Master Code *	● ○ ○
2. Select KwikLearn	0 #	● ● ○
3. Enter address	0 #	● ● ●
4. Enter new code	Code #	○ ○ ●

Example:

Replace the default master code 1234 with a new master code, 3781

		INDICATOR LED's
		○ ○ ●
1. Enter Program mode	* Master Code *	● ○ ○
2. Select KwikLearn	0 #	● ● ○
3. Enter address	0 #	● ● ●
4. Enter new code	3 7 8 1 #	○ ○ ●

Adds a new access code at a specified address, assigns which outputs the code must activate, and how many accesses are allowed before the code becomes invalid.

Enter the following keystrokes:

		INDICATOR LED's
		○ ○ ☀
1. Enter Program mode	⊛ Master Code ⊛	☀ ○ ○
2. Select Add menu	① #	☀ ☀ ○
3. Enter user address	Address #	☀ ☀ ☀
4. Enter access code	Code #	○ ☀ ☀
5. Select outputs	[Output] # †	○ ☀ ☀
6. Assign outputs	#	○ ○ ☀
7. Enter access limit	[Accesses] # ‡	☀ ☀ ○
8. Exit Add menu	#	☀ ○ ○
9. Exit Program mode	#	○ ○ ☀

† Repeat step 5 for additional outputs.

‡ Repeat steps 3 - 7 for additional users.

Notes:

- If no output is specified, the relay output is selected.
- If the number of access are not specified in step 7, unlimited access is set. Care must be taken to ensure the desired access limit is correctly applied. **NB: If unlimited accesses are required, only enter # at step 7.**

Example:

Add access code 527 into address 10. Code must operate

output 2. Code is valid forever. (Master code = 1234)

		INDICATOR LED's		
		○	○	☀
Enter Program mode	* 1 2 3 4 *	☀	○	○
Select Add menu	1 #	☀	☀	○
Enter user address	1 0 #	☀	☀	☀
Enter access code	5 2 7 #	○	☀	☀
Select outputs	2 #	○	☀	☀
Assign outputs	#	○	○	☀
Enter access limit	#	☀	☀	○
Exit Add menu	#	☀	○	○
Exit Program mode	#	○	○	☀

Example:

Add access code 93523 into address 10. Code must operate outputs 1 and 3. Code is valid for 2 uses. (Master code = 1234)

		INDICATOR LED's		
		○	○	☀
Enter Program mode	* 1 2 3 4 *	☀	○	○
Select Add menu	1 #	☀	☀	○
Enter user address	1 0 #	☀	☀	☀
Enter access code	9 3 5 2 3 #	○	☀	☀
Select outputs	1 # 3 #	○	☀	☀
Assign Outputs	#	○	○	☀
Enter access limit	2 #	☀	☀	○
Exit Add menu	#	☀	○	○
Exit Program mode	#	○	○	☀

Deletes an access code at a specified address.

Enter the following keystrokes:

		INDICATOR LED's
		○ ○ ☀
1. Enter program mode	⌘ Master Code ⌘	☀ ○ ○
2. Select Delete menu	2 #	☀ ☀ ○
3. Enter user address	Address # †	☀ ☀ ○
4. Exit Delete menu	#	☀ ○ ○
5. Exit Program mode	#	○ ○ ☀

† Repeat step 3 to delete additional user codes.

Note:

If Address is specified as 0, all access codes will be deleted, and the master code will revert to 1234.

Example:

Delete access code at address 99. (Master code = 1234)

		INDICATOR LED's
		○ ○ ☀
Enter Program mode	⌘ 1 2 3 4 ⌘	☀ ○ ○
Select Delete menu	2 #	☀ ☀ ○
Enter user address	9 9 #	☀ ☀ ○
Exit Delete menu	#	☀ ○ ○
Exit Program mode	#	○ ○ ☀

Example:

Delete all access codes. (Master code = 1234)

		INDICATOR LED's		
		○	○	☀
Enter Program mode	⋆ 1 2 3 4 ⋆	☀	○	○
Select Delete menu	2 #	☀	☀	○
Enter user address	0 #	☀	☀	○
Exit Delete menu	#	☀	○	○
Exit Program mode	#	○	○	☀

Example:

Delete access code at address 54 and 87. (Master code = 1234)

		INDICATOR LED's		
		○	○	☀
Enter Program mode	⋆ 1 2 3 4 ⋆	☀	○	○
Select Delete menu	2 #	☀	☀	○
Enter user address	5 4 #	☀	☀	○
Enter user address	8 7 #	☀	☀	○
Exit Delete menu	#	☀	○	○
Exit Program mode	#	○	○	☀

Sets the output pulse time of the output channels. Default setting is 1 second pulse.

Enter the following keystrokes:

		INDICATOR LED's
		○ ○ ●
1. Enter Program mode	* Master Code *	● ○ ○
2. Select Output menu	3 #	● ● ○
3. Enter Output channel	Channel #	● ● ●
4. Enter pulse time	Seconds # †	● ● ○
5. Exit Output menu	#	● ○ ○
6. Exit Program mode	#	○ ○ ●

† Repeat step 3 & 4 for additional channels.

Notes:

- A pulse time of 0 seconds will give a latched output.
- Maximum pulse time is 255 seconds.

Example:

Set Output 1 to a 1 second pulsed output.
(Master code = 1234)

		INDICATOR LED's
		○ ○ ●
Enter Program mode	* 1 2 3 4 *	● ○ ○
Select Output menu	3 #	● ● ○
Enter Output channel	1 #	● ● ●

Enter pulse time	① #	☀ ☀ ○
Exit Output menu	#	☀ ○ ○
Exit Program mode	#	○ ○ ☀

Example:

Set Output 1 to latch, Output 2 to 5s pulse, and Output 3 to 1s pulse. (Master code = 1234)

		INDICATOR LED's
		○ ○ ☀
Enter Program mode	* ① ② ③ ④ *	☀ ○ ○
Select Output menu	③ #	☀ ☀ ○
Enter Output channel	① #	☀ ☀ ☀
Enter pulse time	① #	☀ ☀ ○
Enter Output channel	② #	☀ ☀ ☀
Enter pulse time	⑤ #	☀ ☀ ○
Enter Output channel	③ #	☀ ☀ ☀
Enter pulse time	① #	☀ ☀ ○
Exit Output menu	#	☀ ○ ○
Exit Program mode	#	○ ○ ☀

4 Setting the anti-hack parameters

Sets the number of wrong access codes the unit will accept before becoming inactive, and the time for which the unit will remain inactive. Default number of wrong codes = 3. Default reset time = 60 seconds.

Enter the following keystrokes:

		INDICATOR LED's
1. Enter Program mode	* Master Code *	○ ○ ☀
2. Select Lockout menu	4 #	☀ ○ ○
3. Enter No. of codes	Wrong Codes #	☀ ☀ ☀
4. Enter Reset time	Seconds #	☀ ○ ○
5. Exit Program mode	#	○ ○ ☀

Notes:

- If the Number of wrong codes is set to 0, the unit will accept an unlimited number of wrong codes.
- If the Reset time is set to 0, the unit can only be reset by removing the power.

Example:

Set Wrong Code Alarm to activate after 5 incorrect codes have been entered. Unit must reactivate after 30 seconds.

(Master code = 1234)

		INDICATOR LED's
Enter Program mode	* 1 2 3 4 *	○ ○ ☀

Select Lockout menu	4 #	☀ ☀ ○
Enter No. Of codes	5 #	☀ ☀ ☀
Enter Reset time	3 0 #	☀ ○ ○
Exit Program mode	#	○ ○ ☀

Example:

Disable the Wrong Codes alarm feature.

(Master code = 1234)

		INDICATOR LED's
		○ ○ ☀
Enter Program mode	* 1 2 3 4 *	☀ ○ ○
Select Lockout menu	4 #	☀ ☀ ○
Enter No. Of codes	0 #	☀ ☀ ☀
Enter Reset time	1 #	☀ ○ ○
Exit Program mode	#	○ ○ ☀

5 Setting the key wipeout timer

Sets the number of seconds for which keystrokes remain valid. This ensures that if a partial code has been entered, it is wiped out of the keypad buffer after a preset time, and must be re-entered in its entirety. The clearing of the keypad buffer is indicated by the keypad back light changing from bright (active) to dim (standby). Default wipeout timer = 15 seconds.

Enter the following keystrokes:

	INDICATOR LED's
1. Enter Program mode (*) Master Code (*)	○ ○ ☀
2. Select Wipeout menu (5) (#)	☀ ○ ○
3. Enter Wipeout time Seconds (#)	☀ ☀ ○
4. Exit Program mode (#)	○ ○ ☀

Notes:

- If the Wipeout time is set to 0, key wipeout will be disabled.

IMPORTANT

Disabling the key wipeout timer will:

- Compromise the security of the system.
 - Cause a code entry to be incorrectly recognised as a **WRONG CODE** if an incomplete code was previously entered.
- If key wipeout is disabled, the keypad back light will remain in bright mode.

Example:

Set the Key wipeout time to 15 seconds.

(Master code = 1234)

		INDICATOR LED's		
		○	○	☀
Enter Program mode	⊕ 1 2 3 4 ⊕	☀	○	○
Select Wipeout menu	5 #	☀	☀	○
Enter Wipeout time	1 5 #	☀	○	○
Exit Program mode	#	○	○	☀

Example:

Disable the key wipeout time:

(Master code = 1234)

		INDICATOR LED's		
		○	○	☀
Enter Program mode	⊕ 1 2 3 4 ⊕	☀	○	○
Select Wipeout menu	5 #	☀	☀	○
Enter Wipeout time	0 #	☀	○	○
Exit Program mode	#	○	○	☀

Sets the conditions under which the Alarm channel (Output 3) will activate. Also sets the anti-default and tone mute features.

The following alarm conditions can be set:

Duress (Code + 1) (Default = off):

Adding 1 to the last digit of an access code activates the unit as normal, but also activates the alarm channel. This is used if entering under duress. E.g. Access code is 1234: Entering 1235 gives access, but also activates the alarm channel.

Alarm (* + #) (Default = off):

Pressing the (*) and (#) keys simultaneously activates the alarm channel.

Wrong codes (Default = off):

When the number of wrong codes is exceeded, the alarm channel is activated.

Anti Default feature (Default = off):

Setting this feature prevents the master code and system parameters from being reset by the defaulting features.

Tone Mute feature (Default = off):

Setting this feature turns off the audible feedback when

entering a code. This prevents an eavesdropper from determining the number of digits in the code. Tones will still be present in programming mode.

Enter the following keystrokes:

		INDICATOR LED's
Enter Program mode	* Master Code *	○ ○ ●
Select Alarm menu	6 #	● ○ ○
Set (Code + 1)	[0 or 1] #	● ● ●
Set (* + #)	[0 or 1] #	○ ● ●
Set (Wrong Codes)	[0 or 1] #	○ ○ ●
Set Anti Default	[0 or 1] #	○ ○ ○
Set Tone Mute	[0 or 1] #	● ○ ○
Exit Program mode	#	○ ○ ●

Note:

- 0 # turns function off, 1 # turns function on, # leaves function unchanged.

Example:

Enable alarm on Code+1. Clear all other functions.

(Master code = 1234)

		INDICATOR LED's
Enter Program mode	* Master Code *	○ ○ ●
Select Alarm menu	6 #	● ○ ○
Set (Code + 1)	1 #	● ● ●

Clear (* + #)	0 #	○ ● ●
Clear (Wrong Codes)	0 #	○ ○ ●
Clear Anti Default	0 #	○ ○ ○
Clear Tone Mute	0 #	● ○ ○
Exit Program mode	#	○ ○ ●

Example:

Set Alarm on Wrong Codes. Set Tone Mute. Leave all other functions unchanged.

(Master code = 1234)

		INDICATOR LED's
		○ ○ ●
Enter Program mode	* Master Code *	● ○ ○
Select Alarm menu	6 #	● ● ○
Skip (Code + 1)	#	● ● ●
Skip (* + #)	#	○ ● ●
Set (Wrong Codes)	1 #	○ ○ ●
Skip Anti Default	#	○ ○ ○
Set Tone Mute	1 #	● ○ ○
Exit Program mode	#	○ ○ ●

Backing up the unit

Backs up all the user access codes as well as system settings to the optional CP108 Backup Memory Module. This allows the system to be easily restored in the unlikely event of system failure.

Procedure for backing up the unit:

Remove power. Plug the CP108 into the socket provided. Reapply power. All three LEDs will now be on. Press ① on the keypad. The GREEN LED will begin to flash, indicating that the memory is being backed up. When the backup is complete, a beep will be heard, and the YELLOW and GREEN LEDs will turn off. Remove the Memory Module, and keep it in a safe place.

Note:

- *Backing up to a Memory Module will overwrite any information that was previously contained in that Memory Module.*

Restoring the unit

Restores all the user access codes as well as system settings from the optional CP108 Backup Memory Module.

Procedure for restoring the unit:

Remove power. Plug the CP108 into the socket provided. Reapply power. All three LEDs will now be on. Press ③ on the keypad. The YELLOW LED will begin to flash, indicating that the memory is being restored. When the restore is complete, a beep will be heard, and the YELLOW and GREEN LEDs will turn off. Remove the Memory Module, and keep it in a safe place.

Note:

- *Restoring from a Memory Module will overwrite any information that was previously contained in the SmartGUARD unit. In addition, the master code will be reset to 1234.*

Defaulting the unit

Both the master code and the system parameters (timers, alarm functions etc.) can be reset to factory defaults. This is useful when the master code has been forgotten, or the system parameters are in an unknown state.

Defaulting the Master Code:

Remove power. Re-apply power while holding the ① key down for 2 seconds. A beep will then follow, indicating that the master code has been reset to 1234.

Defaulting the System Parameters:

Remove power. Re-apply power while holding the ② & ③ keys down for 2 seconds. A beep will then follow, indicating that the system parameters have been reset to the following factory defaults:

Output timers:	1s pulse
Wrong codes:	3
Wrong code reset:	60s
Wipeout timer:	15s
Security parameters:	All OFF

NOTE:

- *Defaulting is not possible if the anti-default option has been set (see page 16). In this case, if the master code has been lost, the system must be restored from a backup to reset the master code to 1234.*

Typical Mounting Instructions:

1. Remove retaining screw cover and screws.
2. Insert screwdriver blade into groove provided between the cover and back panel. Lever screwdriver forward to separate cover and back panel.

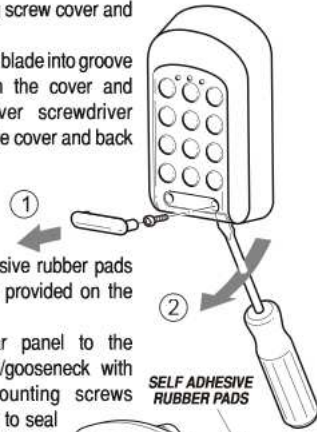

3. Fix the self adhesive rubber pads into the recesses provided on the rear panel.
4. Attach the rear panel to the mounting surface/gooseneck with the supplied mounting screws provided. Be sure to seal all mountings with silicone sealant.

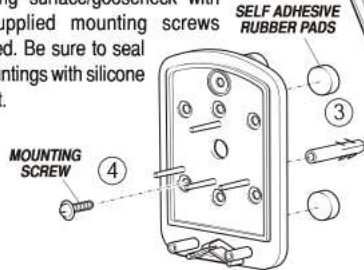

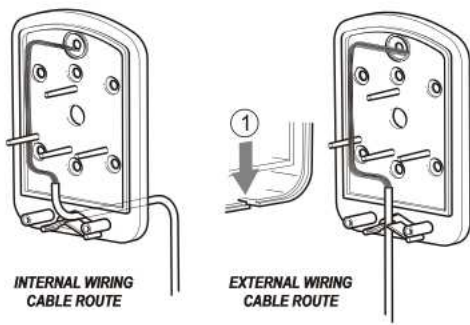

1. In the case of the wiring being mounted externally, knock out the tab in the base of the cover (1) to allow the cable to pass through.

2. If the keypad is to be mounted on a gooseneck, or if the cable must pass through the centre of the back panel, knock out the tab (2).

3. In both the above cases, ensure the cable entry points are sealed with silicon sealant.

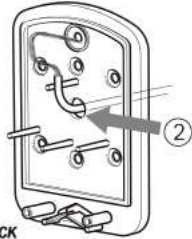

GOOSENECK
CABLE ROUTE

Fitting the optional anti-tamper switch

1. Solder the wires from an alarm system to the relevant contacts on the anti-tamper switch.
2. Slide the anti-tamper switch into the switch carrier. Ensure that the retaining pins in the switch carrier pass through the matching holes in the switch.
3. Slide the switch and carrier assembly into the grooves provided in the keypad cover.

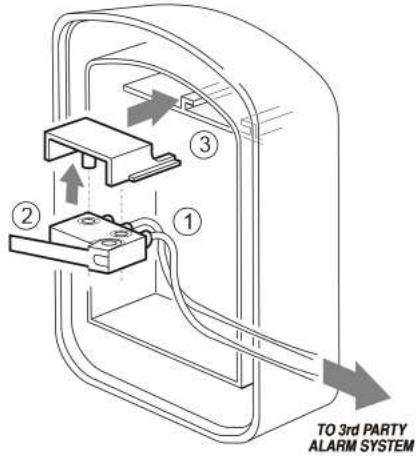

Typical Connection Diagram:

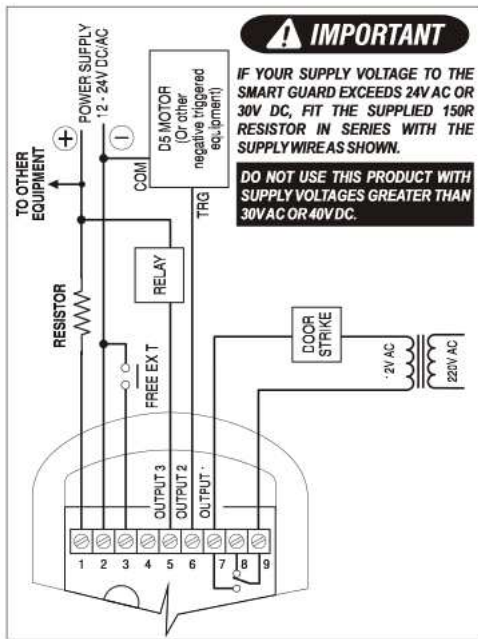

Glossary

ACCESS CODE

The code number the user will enter to gain access. It can range in length from 1 to 10 digits.

ADDRESS / USER ADDRESS

The location where the user's code is stored in the keypad memory. It can be any number between 1 and 999. It should be recorded, allowing the user code to be removed from the memory later if necessary.

MASTER CODE

The code number required for programming the keypad. It is stored in user address 0. THE DEFAULT MASTER CODE OF A NEW UNIT IS 1234. ***FOR SECURITY REASONS, THE INSTALLER SHOULD CHANGE THIS CODE AT THE TIME OF INSTALLATION.*** Refer to page 5 for instructions on how to change the master code.

ENTER KEY #

In order to gain access, the user code must be followed by a #.

Installation Information:

Master Code: _____

Output 1 to: _____

Output 2 to: _____

Output 3 to: _____

Installer's Name: _____

Installer's Telephone: _____

Installer's Address: _____

Complete the *INSTALLATION INFORMATION* above for future reference.
Keep this manual in a secure place.

For your convenience you will find an *ADDRESS REGISTER* included in your SmartGUARD packaging. Use this *ADDRESS REGISTER* to record which addresses have been assigned, their access code and which output will be activated by that address.

KEEP THE ADDRESS REGISTER
IN A SECURE PLACE

The supplied Address Register will record the first 500 addresses, from 0 to 499. Should you require a second Address Register to record the next 500 addresses, i.e. address 500 to 999, please contact your nearest CENTURION SYSTEMS branch or distributor.

Manufactured by:



CENTURION SYSTEMS
148 Epsom Avenue, North Riding, Randburg,
SOUTH AFRICA

Tel: + 27(0)11 699-2400 Fax + 27(0)11 704-3412

www.centsys.co.za
email: sales@centsys.co.za
info@centsys.co.za



Represented in your area by:

Centurion Systems reserves the right to change any product without prior notice.
